

form 1

f10 Sideboard

Montageanleitung Assembly instruction

Inhaltsverzeichnis

Pflegehinweise	3
Korpusmontage assembly of carcase	4
Seitliche Verbindung assembly sidewise	4
Wandhängend Wall-mounted	5
Ausrichten Adjusting	7
Verstärkungsschiene Reinforcement bar	7
Offenes Fach Open compartment	8
Montage Abdeckung Assembly cover panel	10
Montage Abdeckplatte Assembly cover panel	10
Montage untere Abdeckplatte Assembly bottom cover panel	11
Montage Außenseite bei gestapelten Korpusen	
Assembly side panel for stacked carcasses	12
Montage Gestelle Assembly base plate	13
Bodenplatte base plate	13
Fußgestell, Kufengestell, Profilgestell Runner frame, profile frame	14
Rundrohrfuß round leg	17
Gleiter gliding legs	18
Ausrichten der Fronten Alignment of the fronts	19
Ausrichten der Türen Alignment of the doors	19
Ausrichten der Schubkästen Alignment of the drawers	20
Ausrichten der Klappe Alignment of the flaps	21
Beleuchtung Lighting	22

Pflegehinweise

Lack

Staubentfernung: Staubwedel oder leicht angefeuchtetes Baumwolltuch.

Bitte nicht verwenden: Mittel, die Material auftragen (Wachse / Öle) oder abbauen (scharfe Flüssigreiniger, Scheuerpulver oder Lösungsmittel)

Lacquer

Dust removal: feather duster or slightly moistened cotton, cotton cloth.

Please do not use: Agents that apply material (waxes/oils) or break down (harsh liquid cleaners, scouring powders or solvents).

Furniere

Staubentfernung: leicht feuchtes, weiches und flusenfreies Tuch.

Reinigung immer in Richtung der Maserung!

Stärkere Verschmutzungen und Fettflecken: unverdünnter Schonreiniger (Neutralseife) mit einem weichen, flusenfreien Tuch.

Ganzflächig und ohne Druck arbeiten

Veneers

Dust removal: slightly damp, soft and lint-free cloth.

Always clean in the direction of the grain!

Heavier soiling and grease stains:

undiluted gentle cleaner (neutral soap) with a soft, lint-free cloth.

Work over the entire surface and without pressure

Glas

Fronten mit einem feuchten Tuch (Baumwolle oder Mikrofaser) abwischen, ggf. einen Neutralreiniger (verdünnt mit Wasser) hinzugeben.

Bitte keine alkoholischen Glasreiniger oder konzentrierte Reinigungsmittel einsetzen.

glass

Wipe the fronts with a damp cloth (cotton or microfiber), if necessary add a neutral cleaning agent (diluted with water).

Please do not use alcohol-based glass cleaners or concentrated cleaning agents.

Service

Wenn du einen Kratzer oder eine kleine Beschädigung an deinem Möbel feststellst, lässt sich das häufig mit Lack retuschieren. Bestelle unter info@formeins.de mit Angabe der Farbkennung deines Möbels einfach ein kostenloses Lackfläschchen

Service

If you notice a scratch or minor damage to your furniture

this can often be often retouched with varnish.

Order at info@formeins.de, stating the color code of your furniture, a free bottle of varnish

Korpusmontage assembly of carcass

Seitliche Verbindung assembly sidewise



Beschlagbeutel 1 (Korpusverbindung Standard) fitting bag 1 (standard carcass assembly)



4 x Gewindehülse
4 x threaded sleeve



4 x Gewindeschraube M4×15
4 x threaded bolt M4×15

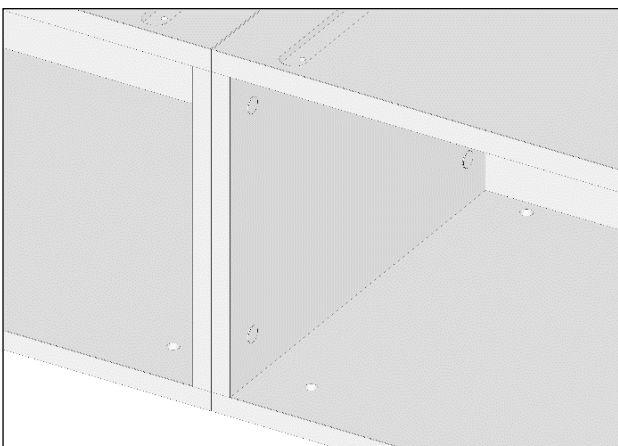

Beschlagbeutel Abdeckkappen (jeweils in passender Farbe) fitting bag covering caps (in matching colour)



Abdeckkappe
Covering cap

Wandhängend Wall-mounted



1x Wandbefestigungsplatte
(teilbar in links und rechts)
1x plate for wall assembly
(divided in left and right)



2 x Abdeckkappen
2 x covering caps

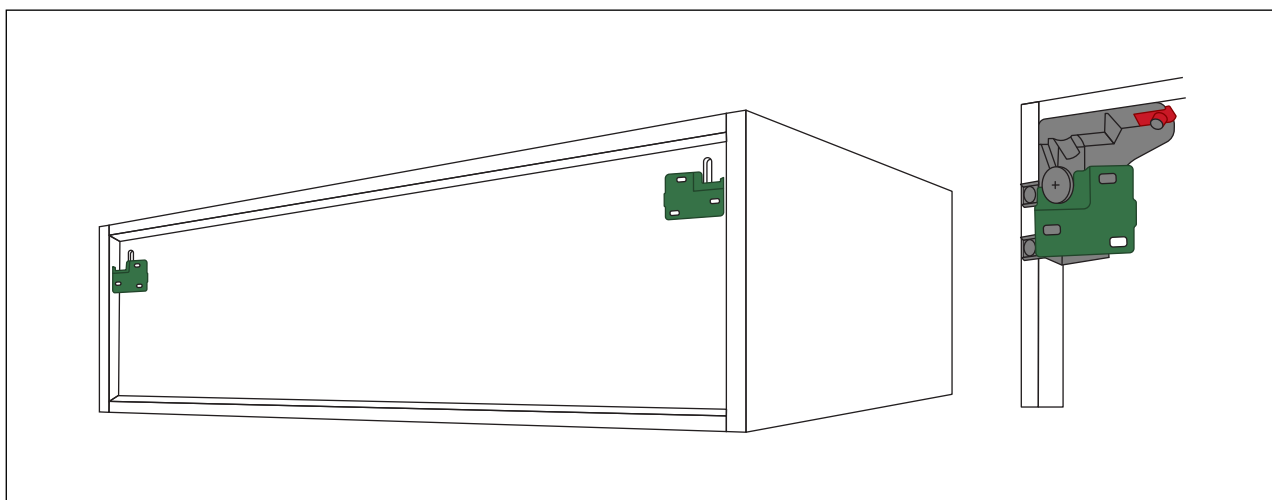

Wandhängebeschläge, Einstellung vom Hersteller
Assembly manufacturer

Wandhängend Wall-mounted

Wandhängebeschläge, Einstellungen adjustments:

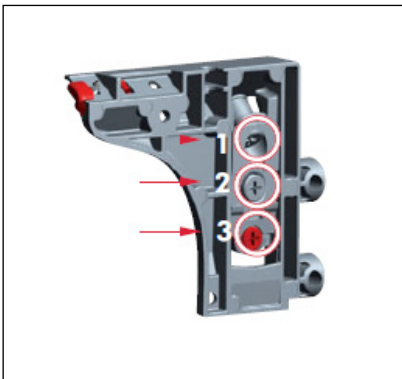

Vertikale Einstellung (13mm):
vertical adjustments (13mm):



Tiefenverstellung (12mm)
in-depth-adjustment (12mm)

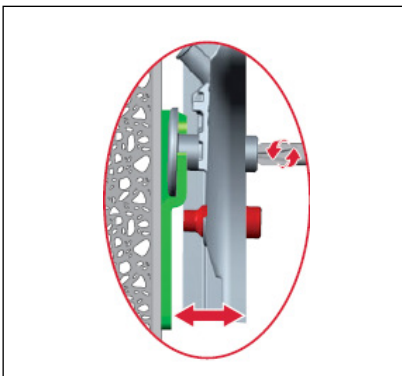

Anti-Aushebesicherung
Anti-turnover locking

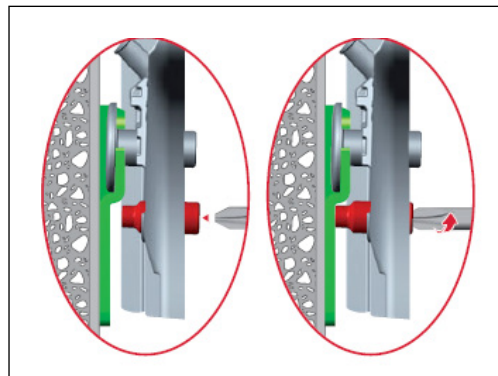

**Bitte stoppen Sie das drehen, wenn der rote
Einsatz an die Platte stößt**
**Stop screwing the red bolt when it touches
the plate**

Ausrichten Adjusting

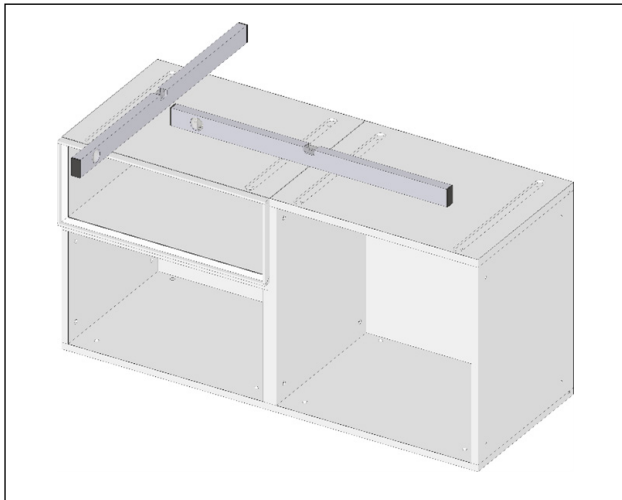

Verstärkungsschiene Reinforcement bar

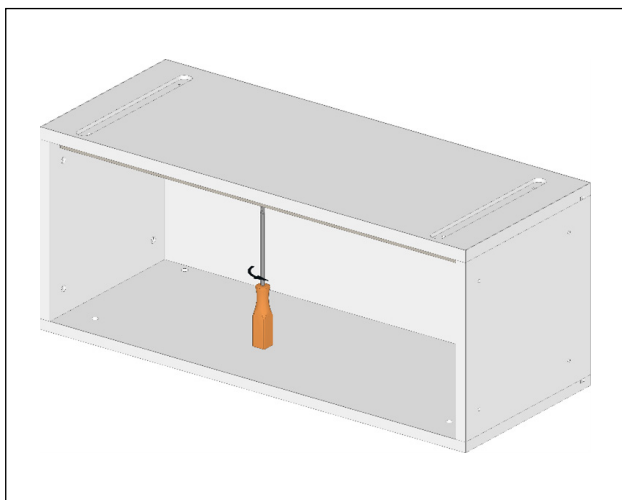

mittige Stellschraube rausdrehen um durch Druck den Deckel gegen Durchhängen zu hindern.
Unscrew the central set screw to prevent the lid from sagging by applying pressure.

Offenes Fach Open compartment

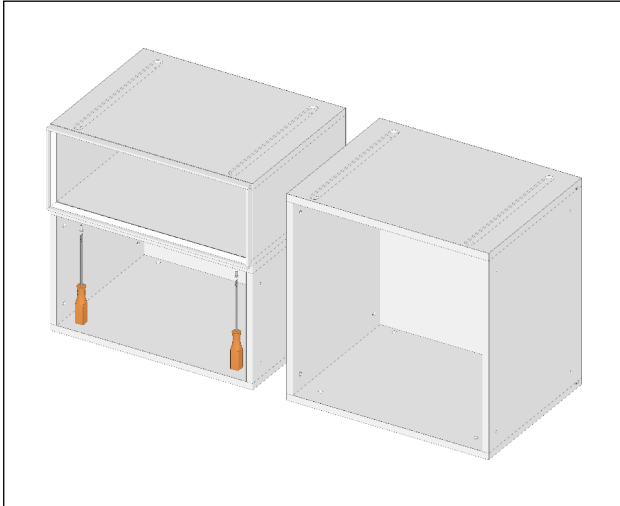

Beschlagbeutel 5 (Korpusverbindung
Stapelvariante)

fitting bag 5 (carcase connection stacked version)



4 x Gewindeschraube M4x15
4 x threaded bolt M4x15

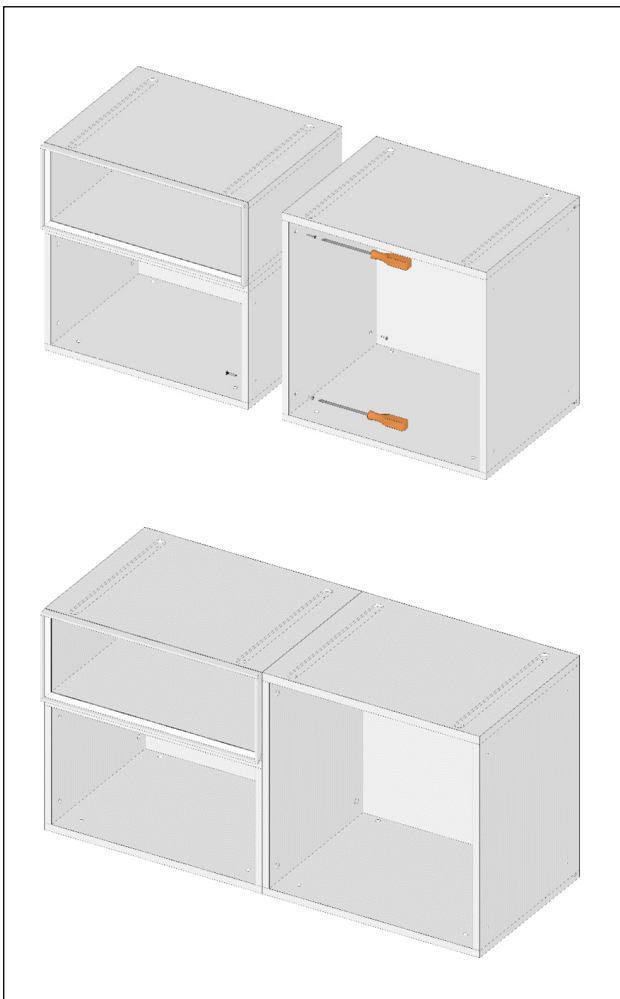

Beschlagbeutel 1 (Korpusverbindung Standard)

fitting bag 1 (standard carcase assembly)



2 x Gewindehülse
2 x threaded sleeve



2 x Gewindeschraube M4x15
2 x threaded bolt M4x15

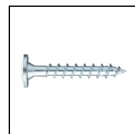

2 x Schraube mit Flachkopf 3x25
2 x screw flat 3 x 25

Offenes Fach Open compartment

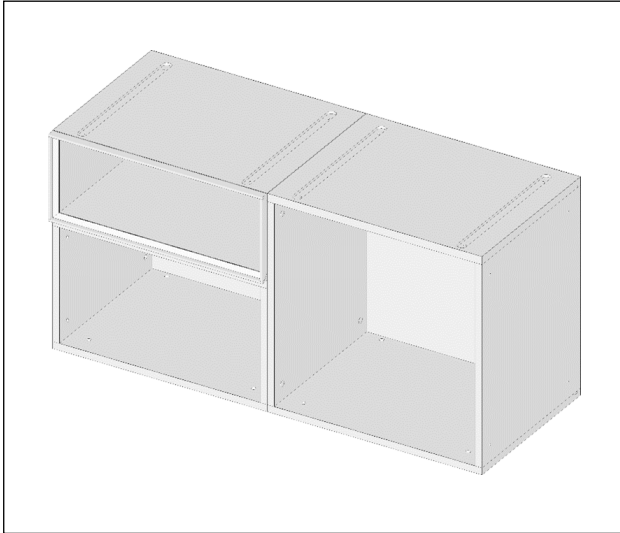

Beschlagbeutel Abdeckkappen (jeweils in passender Farbe)

Fitting bag covering caps (in matching colour)



Abdeckkappe
Covering cap

Montage Abdeckung Assembly cover panel

Montage Abdeckplatte Assembly cover panel

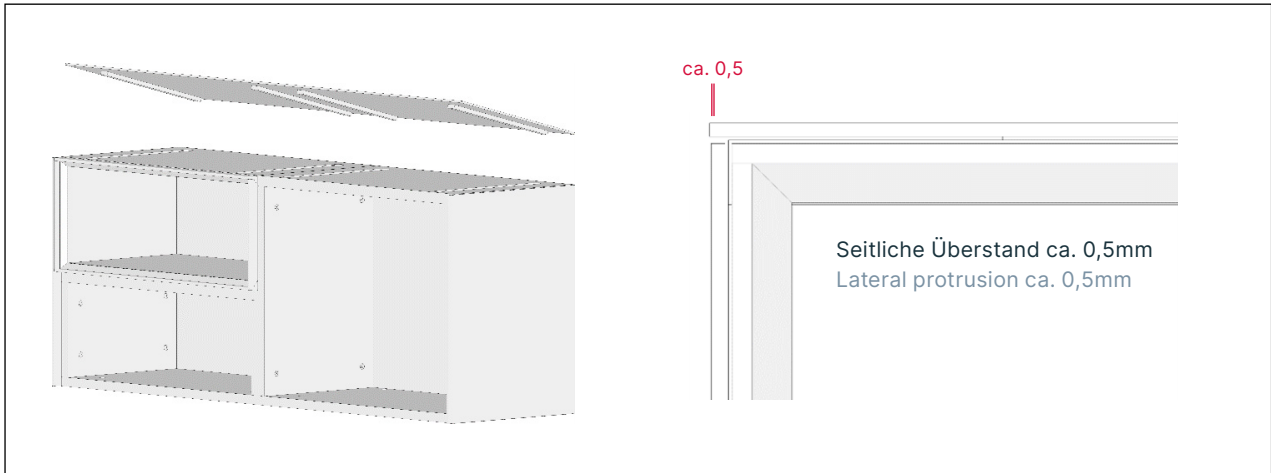

Beschlagbeutel 2 (Muffenbefestigung) fitting bag 2 (sleeve attachment)



4 x Gewindeschraube M4×15
normaler Schrank
4 x threaded screw M4×15 closed front



4 x Gewindeschraube M4×12
offenes Fach
4 x threaded screw M4×15
open compartment

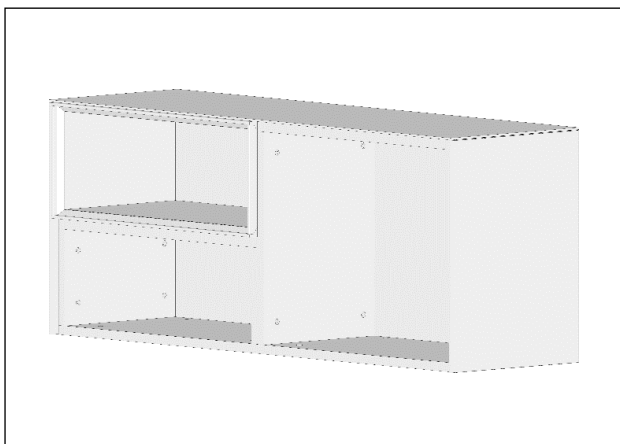

Beschlagbeutel Abdeckkappen (jeweils in passender Farbe) Fitting bag covering caps (in matching colour)



je Korpus 4x Kappe
per carcass 4 caps

Montage untere Abdeckplatte Assembly bottom cover panel

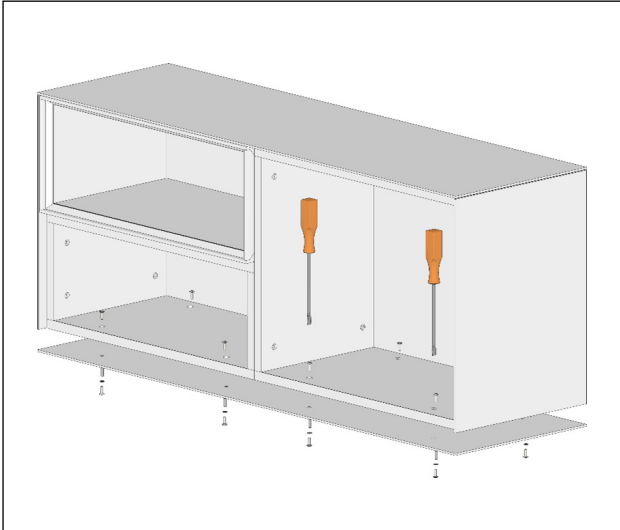

Beschlagbeutel 4 (untere Abdeckplatte) fitting bag 4 (bottom cover panel)



8x/12x Gewindeschraube M4×8
8x/12x Threaded bolt M4×8



4x/6x Gewindehülse
4x / 6x Threaded sleeve

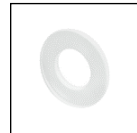

4x/6x Unterlegscheibe
4x/6x flat washer

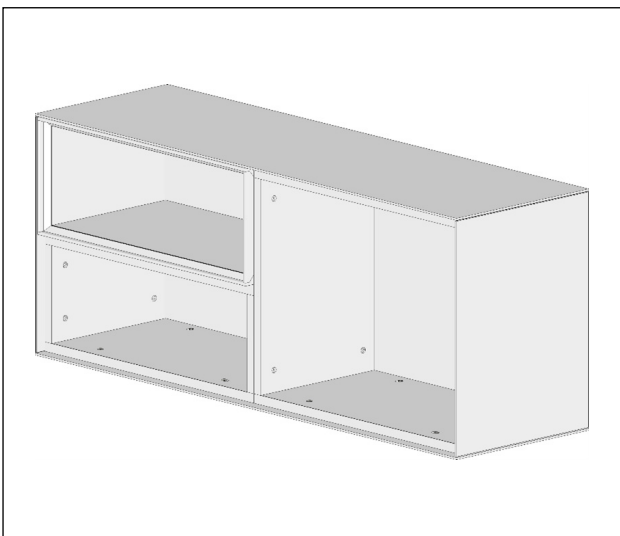

Beschlagbeutel Abdeckkappen (jeweils in passender Farbe) Fitting bag covering caps (in matching colour)



je Korpus 4x Kappe
per carcass 4 caps

Montage Außenseite bei gestapelten Korpusen Assembly side panel for stacked carcasses

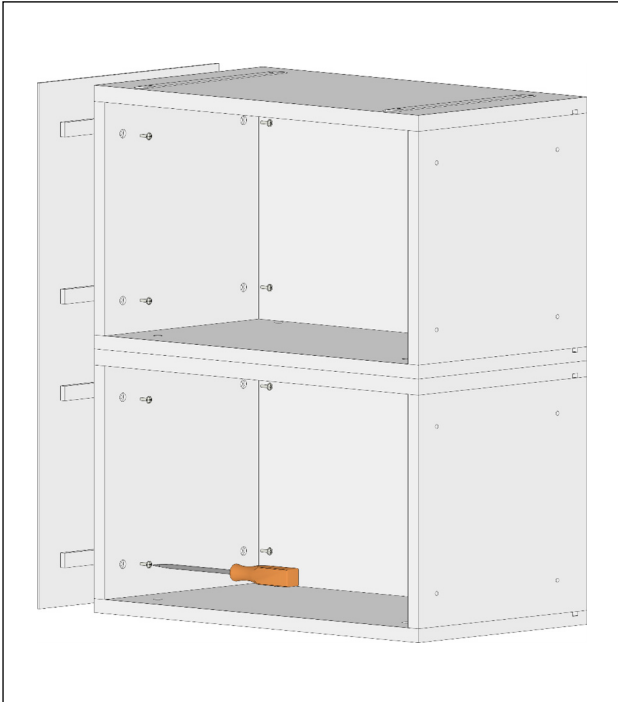

Beschlagbeutel 5 (Korpusverbindung
Stapelvariante)
fitting bag 5 (carcase connection stacked version)



4x Gewindeschraube M4x22
4x Threaded bolt M4x22

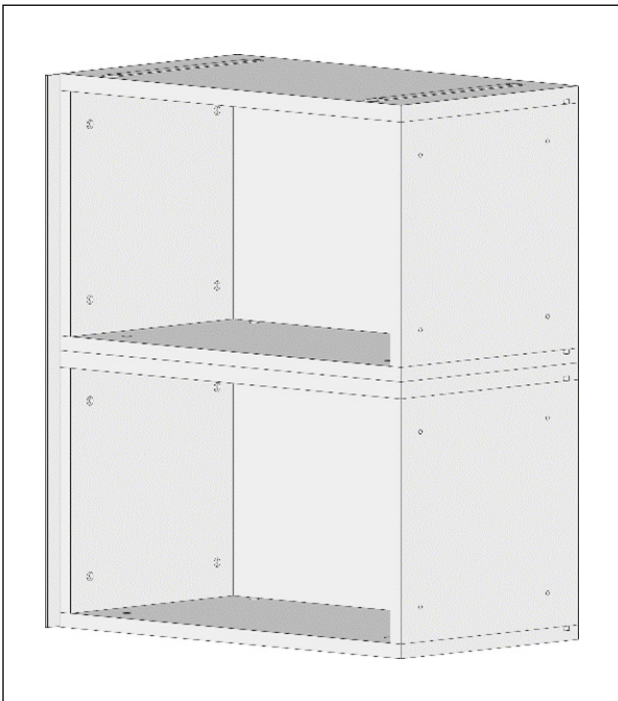

Beschlagbeutel Abdeckkappen (jeweils in passen-
der Farbe)
Fitting bag covering caps (in matching colour)



je Korpus 4x Kappe
per carcase 4 caps

Montage Gestelle Assembly base plate

Bodenplatte base plate

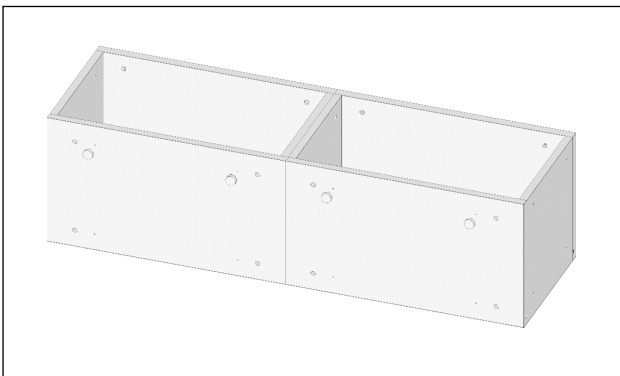
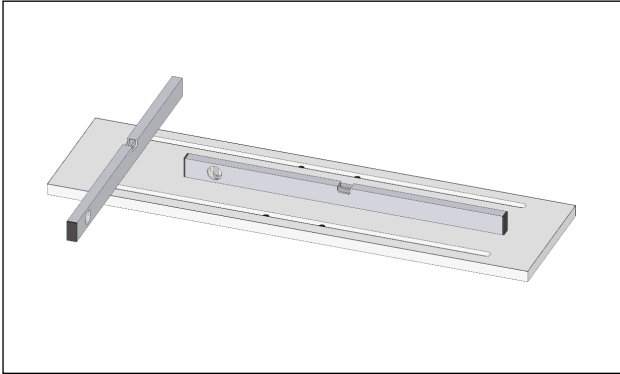

Beschlagbeutel 5 (Korpusverbindung
Stapelvariante)

fitting bag 5 (carcase connection stacked version)

2 x Schraube 3,5×16
2 x screws 3,5×16

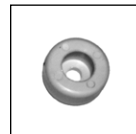

2 x Gleiter
2 x glides

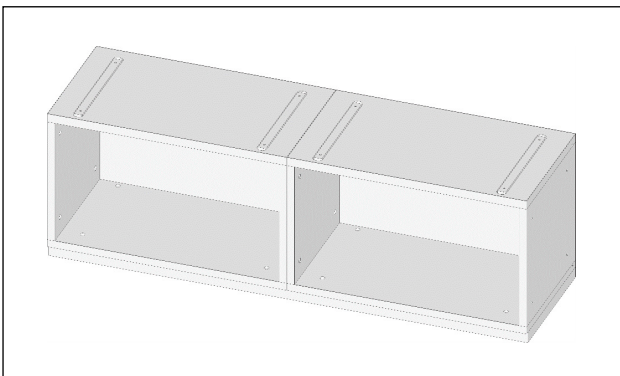

Korpus in Nut stellen (links und rechts bündig)

Put the carcass in the groove (left and right side aligned)

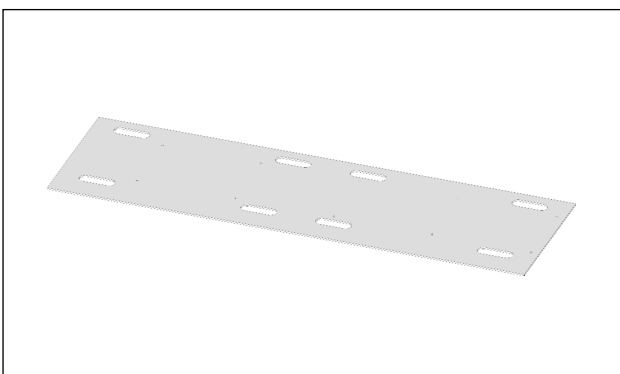

Montage untere Abdeckplatte gleich (hier sind die
Korpuspunkte frei)

Assembly bottom cover panel alike (points of fixation are free)

Fußgestell, Kufengestell, Profilgestell Runner frame, profile frame

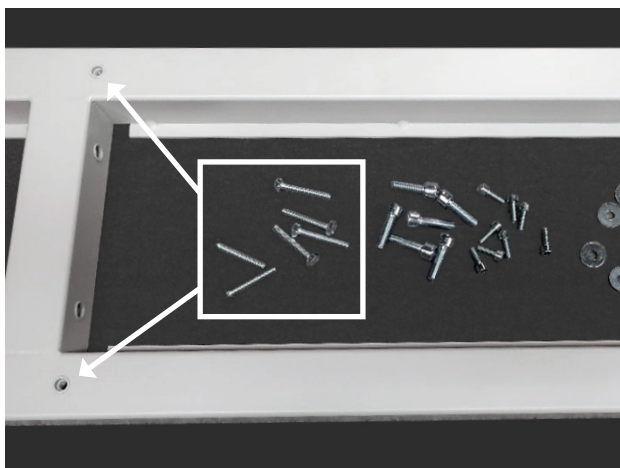

Beschlagbeutel Kommission extra gepackt
Fitting bag per order packed separately

Je Fuß 2x Sechskopfschrauben zur Höhen-
verstellung in Rahmen schrauben
Screw into frame: 2x six-head screws for
height adjustment per foot

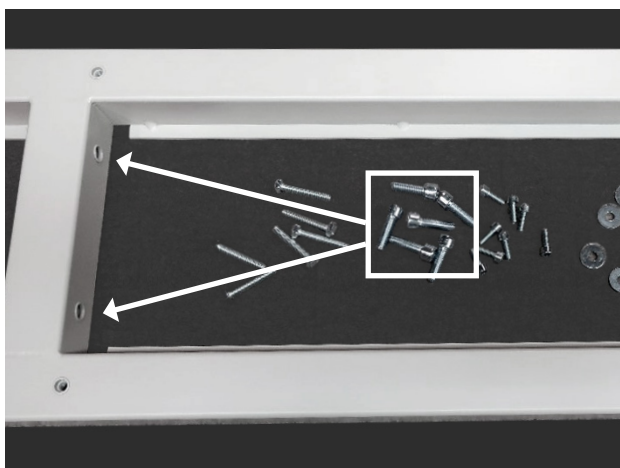

Je Korpus 4x Zylinderkopfschrauben zur
Korpusmontage
Per carcass 4x cylinder head screws with
washer for carcass fixation

Fußgestell, Kufengestell, Profilgestell Runner frame, profile frame

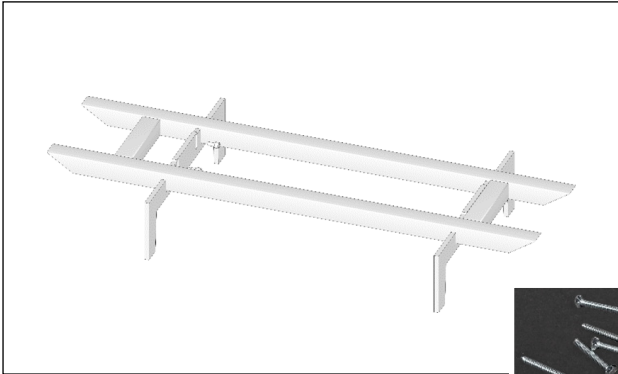

Montage FüÙe am Gestell
Assembly of legs to the frame

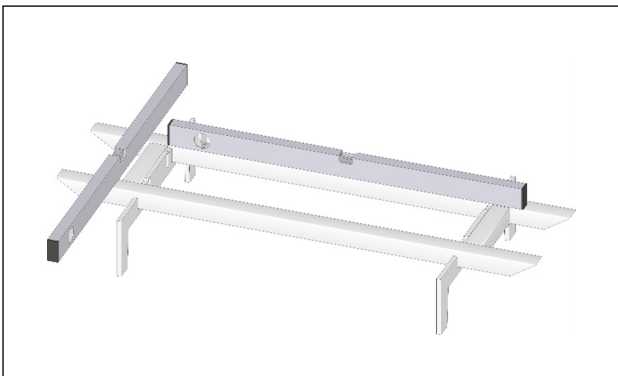

Gestell ausrichten
Align the frame

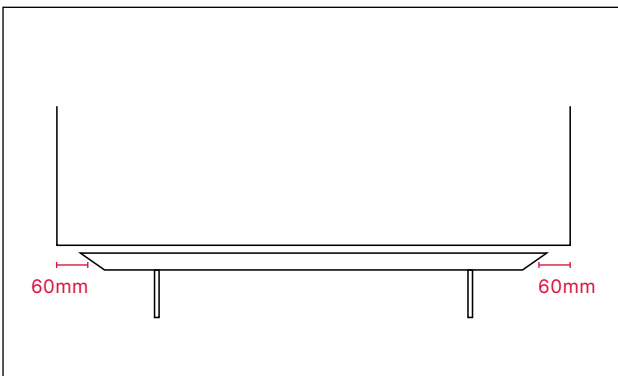

Korpus links und rechts 60mm vermitteln
Position the carcass left and right with a distance of 60mm

Fußgestell, Kufengestell, Profilgestell Runner frame, profile frame

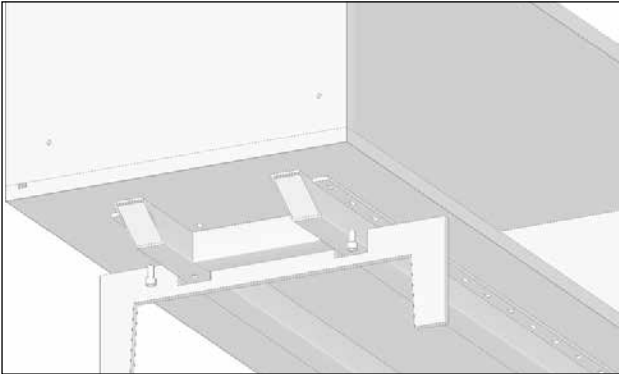

Fußgestell nach vorderem und hinterem
Loch ausrichten
Align foot frame according to the thrilling

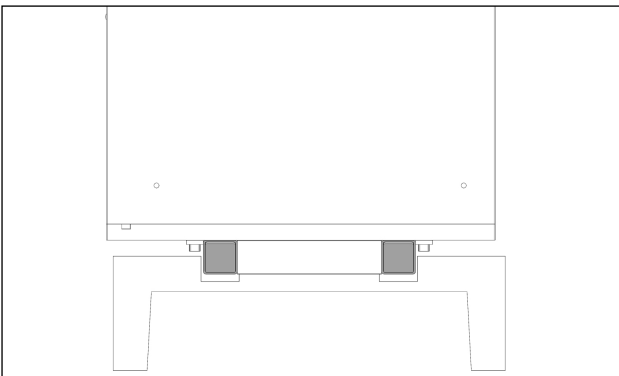

mit Schrauben alle Korpusse verschrauben
Fix all carcasses with screws

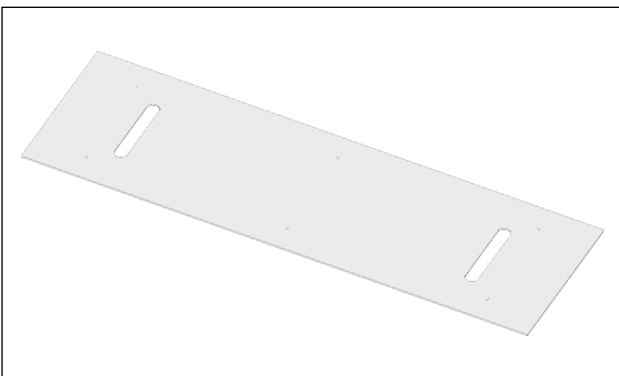

Montage untere Abdeckplatte gleich / hier sind die
Korpuspunkte frei
Assembly bottom panel the same way



8x/12x Gewindeschraube M4×8
8x/12x Threaded bolt M4×8



4x/6x Gewindehülse
4x / 6x Threaded sleeve

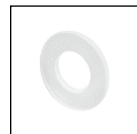

4x/6x Unterlegscheibe
4x/6x flat washer

Rundrohrfuß round leg

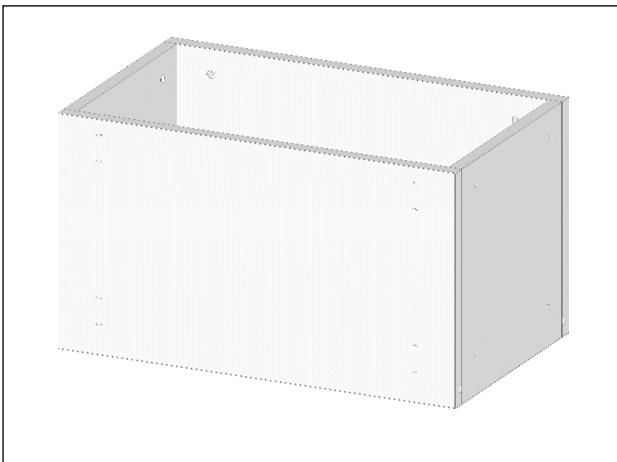
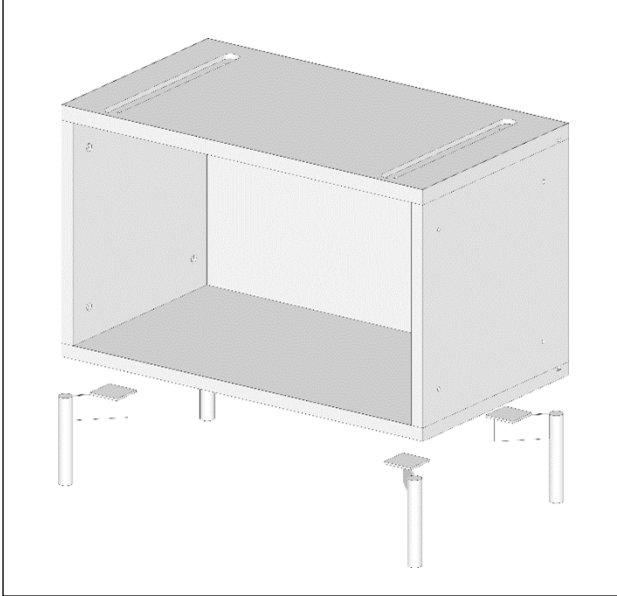

Äußere Löcher = Fuß für die Ecken
Exterior drillings = leg for the corner

Innere Löcher = Kombifuß F10
Interior drillings = legs to combine

Äußere Löcher = Kombifuß F40
Exterior drillings = legs for combination legs f40

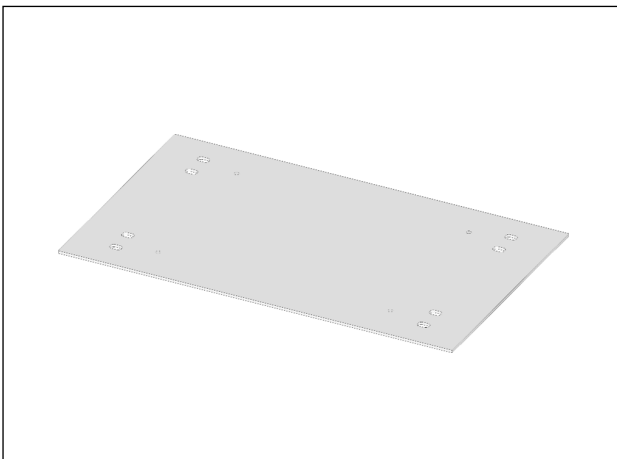

Montage untere Abdeckplatte gleich (hier sind die Korpuspunkte frei)

Assembly bottom cover panel (points of assembly selectable)



8x/12x Gewindeschraube M4x8
8x/12x Threaded bolt M4x8



4x/6x Gewindehülse
4x / 6x Threaded sleeve

Gleiter gliding legs

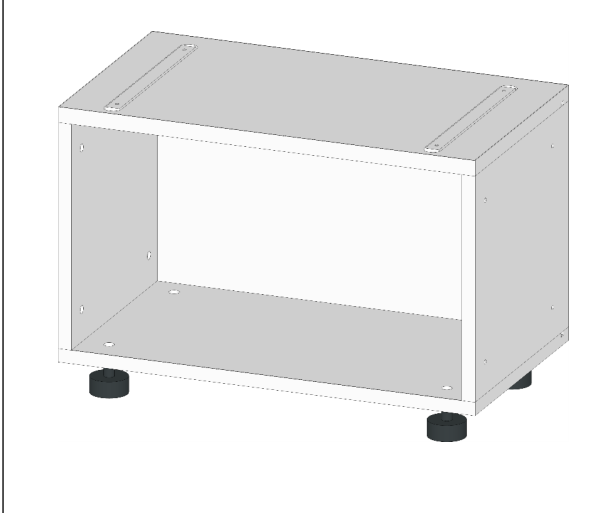

Gleiter unterbauen
assemble gliding legs

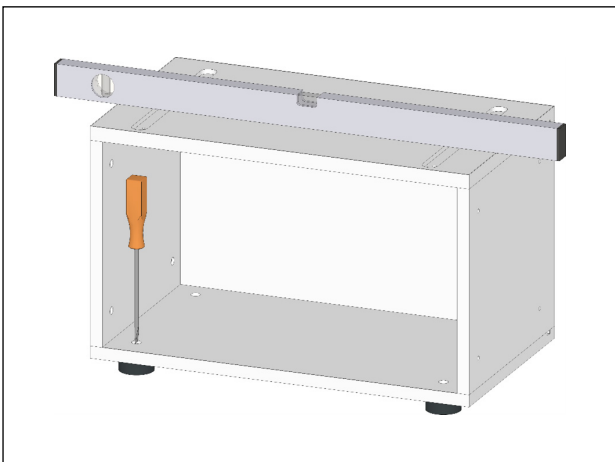

Korpus ausrichten
align the carcass

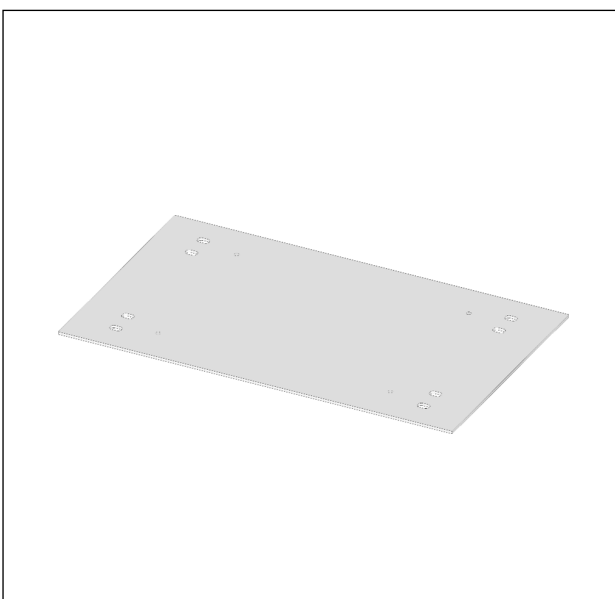

Montage untere Abdeckplatte gleich (hier sind die
Korpuspunkte frei)

Assembly bottom cover panel (points of assembly
selectable)



8x/12x Gewindeschraube M4×8
8x/12x Threaded bolt M4×8



4x/6x Gewindehülse
4x / 6x Threaded sleeve

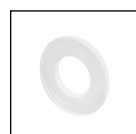

4x/6x Unterlegscheibe
4x/6x flat washer

Ausrichten der Fronten Alignment of the fronts

Ausrichten der Türen Alignment of the doors

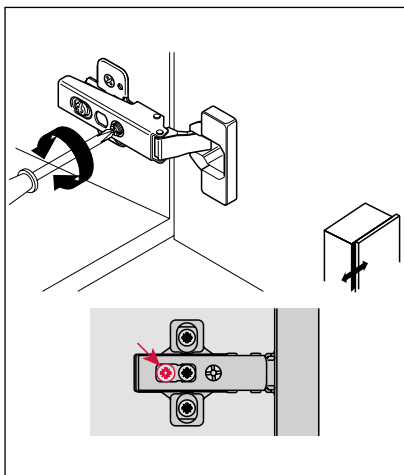

Seitenverstellung:
-1,5 bis 4,5 mm

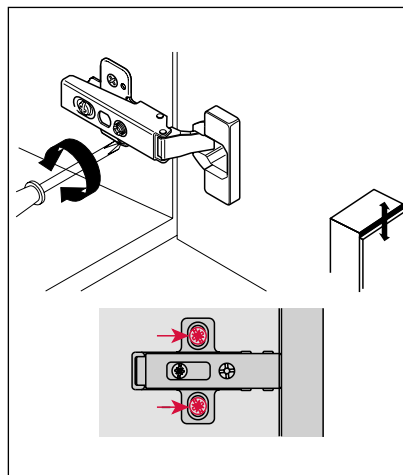

Höhenverstellung:
 ± 2 mm

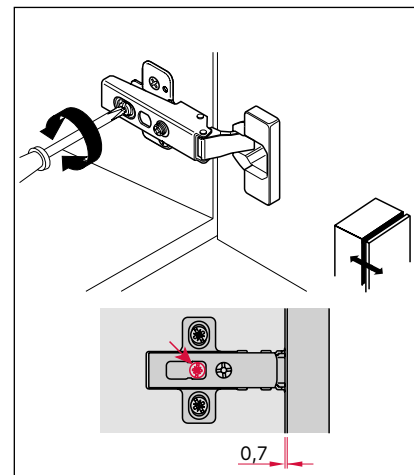

Tiefenverstellung:
-0,5 bis +2,8 mm

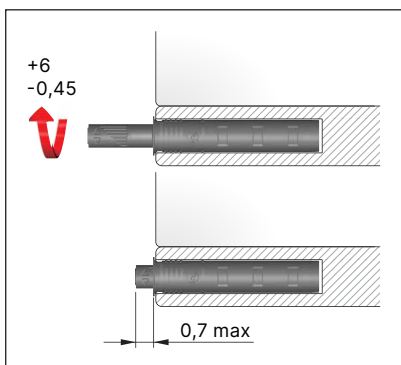

Ausrichten der Schubkästen Alignment of the drawers

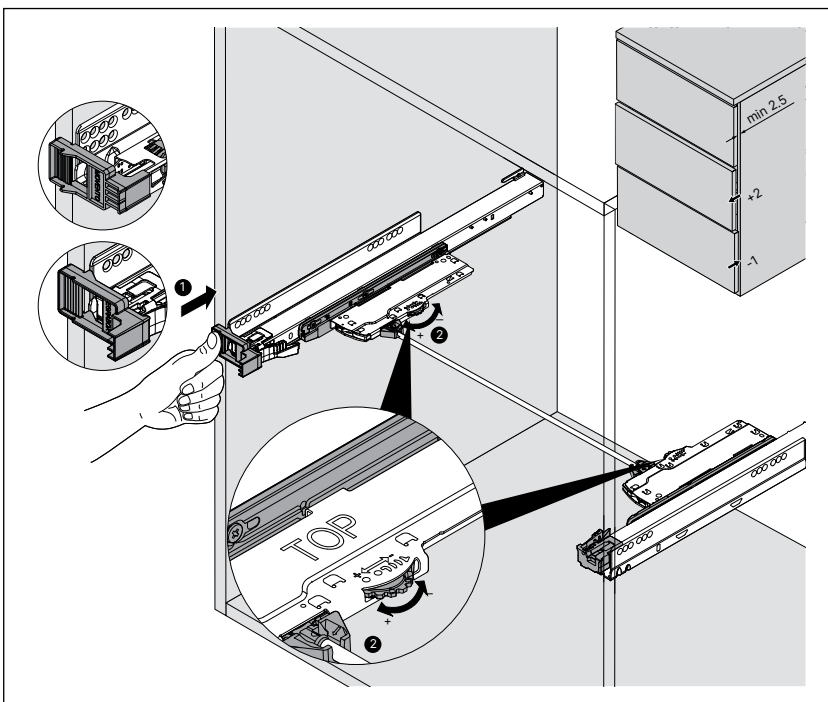
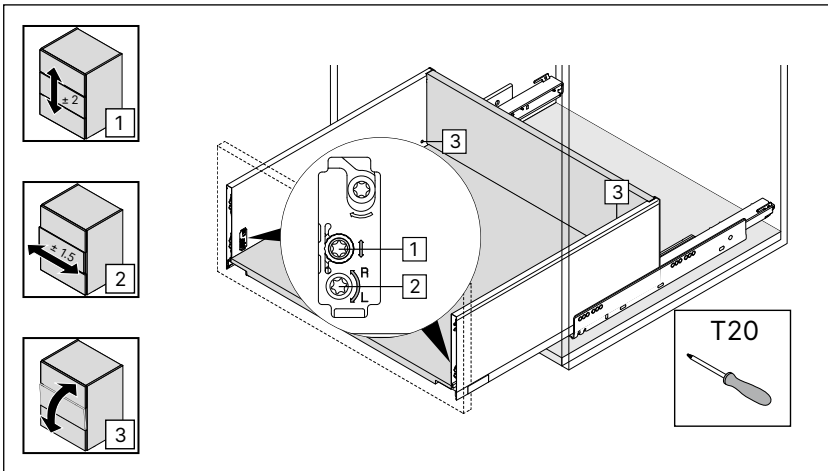

Ausrichten der Klappe Alignment of the flaps

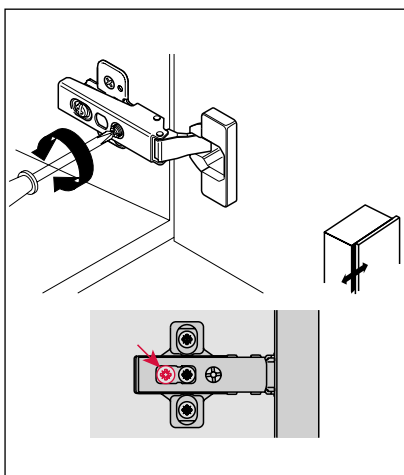
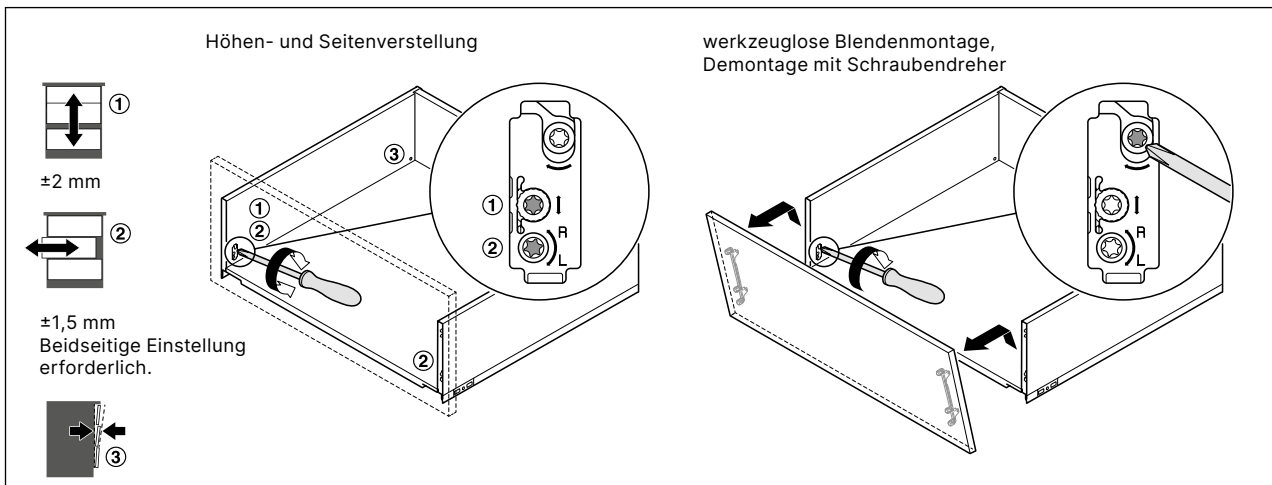

Seitenverstellung:
-1,5 bis 4,5 mm

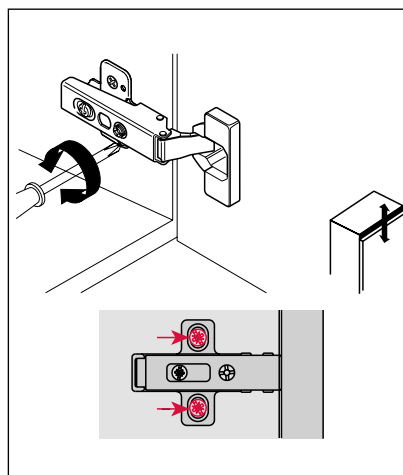

Höhenverstellung:
±2 mm

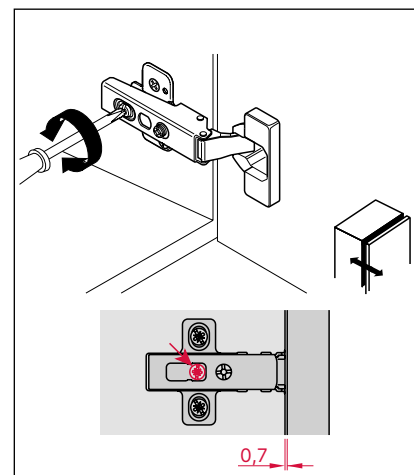

Tiefenverstellung:
-0,5 bis +2,8 mm

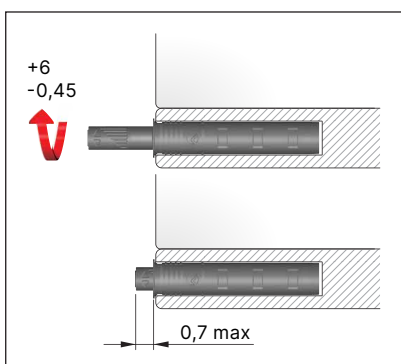

Beleuchtung Lighting

Bei mehreren LED's müssen die Zuleitungen in den Verteiler des Steuergerätes verbunden (Steckverbindung) werden. Fernbedienung ist auf den Empfänger vorinstalliert.

In the case of several LEDs, the supply lines must be connected to the distributor of the control unit (plug connection). Remote control is pre-installed on the receiver.

form 1